

Version Code: A01

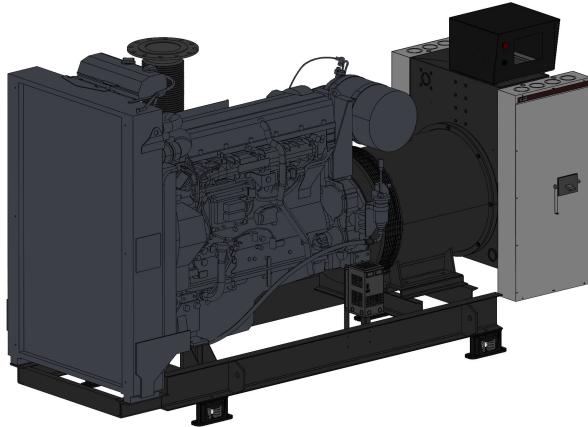

- kWe
- Volt
- Hz / RPM
- Fuel Type
- Application

## RATINGS

|  | VOLTAGE     | Hz | PHASE | PF  | PRIME POWER 105°C |      | STANDBY POWER 130°C |      | Standard Breaker* | Oversized Alternator Available |
|--|-------------|----|-------|-----|-------------------|------|---------------------|------|-------------------|--------------------------------|
|  |             |    |       |     | kW/kVa            | Amps | kW/kVa              | Amps |                   |                                |
|  | 120/240 V   | 60 | 1     | 1   |                   |      |                     |      |                   |                                |
|  | 120/208 V   | 60 | 3     | 0.8 |                   |      |                     |      |                   |                                |
|  | 139/240 V   | 60 | 3     | 0.8 |                   |      |                     |      |                   |                                |
|  | 240/416 V   | 60 | 3     | 0.8 |                   |      |                     |      |                   |                                |
|  | 277/480 V   | 60 | 3     | 0.8 |                   |      |                     |      |                   |                                |
|  | 347/600 V   | 60 | 3     | 0.8 |                   |      |                     |      |                   |                                |
|  | 2400/4160 V | 60 | 3     | 0.8 |                   |      |                     |      |                   |                                |

All ratings are based on ISO-8528-1 and ISO-3046-1 standards. Consult factory for other voltages/ratings.

Prime ratings are capable of 10% overload power for 1-hour in every 12-hours running.

\*Other circuit breaker ratings are available.

## STANDARD EQUIPMENT

### Engine

- Radiator cooled unit mounted
- Pusher Fan & Fan Drive
- Starter & Alternator
- Oil Pump & Filter
- Oil Drain Extension with Valve
- Governor - Electronic Isochronous
- Battery System & Cables
- Air Cleaner (dry single stage)
- Flexible Fuel Connector

### Generator

- Brushless Single Bearing
- Automatic Voltage Regulator
- ± .25% Voltage Regulator
- 4 Pole, Rotating Field
- Class F Temperature Rise
- Class H Insulation
- 100% of Rated Load - One Step
- 5% Maximum Harmonic Content
- Nema MG 1, IEEE and ANIS Standards

### Additional

- Microprocessor Based Digital Controller
- Generator Mounted, NEMA, Control Panel
- Base - Structural Steel
- Main Line Circuit Breaker
- Battery Charger
- Jacket Water Heater with Isolation Valves
- Vibration Isolation Mounts (Spring)
- Single Source Supplier
- 1 YR/1500 HR Standby Warranty



## ENGINE SPECIFICATIONS

Model-----  
 Make-----  
 Aspiration Type-----  
 Cylinder Arrangement-----  
 Combustion Type-----  
 Displacement: in3(L)-----  
 Bore x Stroke: in(mm)-----  
 Compression Ratio-----  
 Governor Type-----  
 0-100% Load Frequency Regulation-----  
 Steady State Frequency Regulation-----  
 Rated Speed:RPM-----  
 Gross Power:BHP(kWm)-----

## FUEL SYSTEM

Fuel Type:-----  
 Connections: Supply (Return)-----  
 Max. Fuel Flow: gph (L/Hr)-----  
 Return Fuel Flow: gph (L/Hr)-----

## FUEL CONSUMPTION

Max Standby gph (L/Hr)-----  
 Max Prime gph (L/Hr)-----  
 75% Standby gph (L/Hr)-----  
 50% Standby gph (L/Hr)-----

## EXHAUST SYSTEM

Engine Manifold Type-----  
 Exhaust Flow: cfm (m3/min)-----  
 Exhaust Temperature: °F (°C)-----  
 Max Back Press: "wc (kPa)-----

## EXHAUST EMISSIONS

Nitrogen Oxides(NOx)-----  
 Particulate Matter (PM)-----  
 NM Hydrocarbon (NMHC)-----  
 Carbon Monoxide (CO)-----  
 EPA Certification-----  
 MOE Standby Compliant-----  
 MOE Non-Emergency Compliant-----

## ELECTRICAL SYSTEM

Starting Voltage: DCV-----  
 Alternator Ratings:AMPS-----  
 Min. Battery: QTY x CCA-----

## LIQUID CAPACITY

Total Oil System: USG (L)-----  
 Engine Coolant: USG (L)-----  
 Engine + Radiator Coolant: USG(L)-----

## LUBRICATION SYSTEM

Type-----  
 Oil Filter: QTY x Type-----  
 Oil Cooler-----

## COOLING SYSTEM

Cooler Type-----  
 Max Ambient Temp: °C-----  
 Water Pump Type-----  
 Fan Type-----  
 Fan Power: HP (kWm)-----

## AIR REQUIREMENTS

Combustion Air: cfm (m3/min)-----  
 Cooling Air: cfm (m3/min)-----  
 Max Back Press: "wc (kPa)-----

## HEAT REJECTION TO AMBIENT AIR

Engine: BTUM (kW)-----  
 600V Alternator: BTUM (kW)-----

## AC ALTERNATOR

Make-----  
 Type-----  
 Exciter Type-----  
 Voltage Regulator-----  
 Winding Insulation-----  
 Stator Pitch-----  
 Bearing: QTY, Type-----  
 Coupling-----  
 Amortisseur Windings-----  
 V. REG. 0-100% Load: %-----  
 Sustained Short Circuit-----

## PEAK MOTOR STARTING kVa (600V Alternator)

Standard Alternator at 35% V-Dip--  
 Standard Alternator at 15% V-Dip--  
 Oversize Alternator at 35% V-Dip--  
 Oversize Alternator at 15% V-Dip--

## AGC-150, ALL IN ONE GENERATOR CONTROLLER



### Six different applications can be programmed:

- Island Mode:** Prime power with stand alone or synchronized generators
- Automatic Mains Failure:** Critical and emergency standby, black-start
- Base-Load Fixed Power:** Fixed kW setpoint with building load
- Peak Shaving:** Generator supplies peak load demand paralleled to the grid
- Load Take-Over:** Load is moved from grid power to generator power
- Mains Power Export:** Generator supplies power back to the grid.

- Easy to use powerful microprocessor controller with graphical anti-glare LDC display
- Synchronize 3 ways: Dynamic, Static, Close before Excitation
- CANbus, R5-485 Modbus RTU, Ethernet Modbus TCP/IP
- Smart Buttons: only the relevant function buttons appear
- 500 Event log / 500 Alarm log
- 3-Phase Sensing with +/- 1% accuracy
- Emulation mode for testing and commissioning

#### Measurements

- AC Voltage (V)
- AC Frequency (Hz)
- AC Current (A)
- Power Factor (PF)
- Real Power (kW)
- Apparent Power (kVA)
- Reactive Power (kvar)
- Oil Pressure (psi)
- Coolant Temperature (C)
- Fuel Level (%)
- Engine Run Time (hrs)
- Engine Speed (rpm)

#### Panel Mounted Devices

- Audible Alarm Horn
- Emergency Stop Button

#### Timers

- Engine Start
- Engine Cooldown
- Oil Pressure Bypass
- Overcrank
- Cycle Crank

#### Digital Outputs

- Generator Running
- Common Alarm
- Common Shutdown

#### Synchronizing Protection

- Sync Check
- Reverse Power
- Breaker External Trip
- Breaker Command Failure
- Under/Over Excitation

#### Alarms

- Not in Auto
- Low Engine Temperature
- High Engine Temperature
- Low Oil Pressure
- Low Fuel Level
- Day Tank Leak
- Underfrequency
- Overcurrent
- Undervoltage
- Low Battery Voltage
- High Battery Voltage
- Weak Battery
- Intake Damper Failure
- ATS Bypass / Not in Auto
- Breaker Not Closed
- Gas Valve Closed

#### Shutdowns

- Overcrank
- Overspeed
- High Engine Temperature
- Low Oil Pressure
- Emergency Stop
- Low Coolant Level
- Underfrequency
- Overcurrent
- Undervoltage
- Overvoltage
- Sensor Fail / Wire-Break
- ECU Comms Fail

#### User Configurable

- 1x Analog Input
- 6x Digital Input
- 3x Digital Input

Complies with CSA-C282-19 Table 1 Requirements

## GENERATOR SPECIFICATIONS

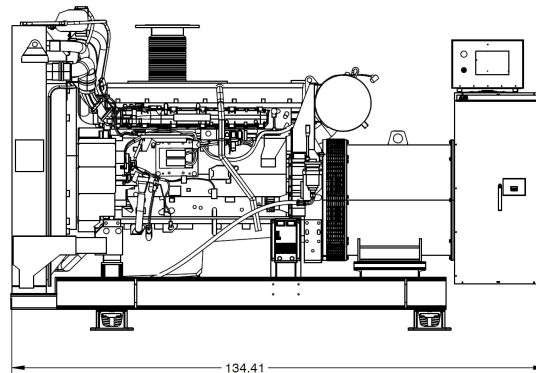
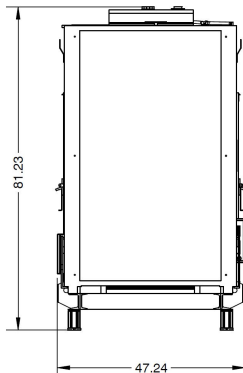

Open Unit Weight: Lbs. (kg)

### STANDARD FEATURES

- Alternator Protection
- Battery, Battery Rack and Cables
- 10A Automatic Battery Charger
- Local Emergency Stop Button
- Oil Drain Extension
- Standard Air Cleaner w/ Restriction Indicator
- Block Heater w/ Thermostat
- Radiator Duct Flange
- Engine Fluids
- Spring Vibration Isolators
- Submittal Package
- Owner's Manual
- 1-Year / 1500-Hour Parts & Labour Standby Warranty

### AVAILABLE OPTIONS

#### Certifications and Specifications Available:

- ESA Electrical Certification
- ULC-S601 Sub-Base Fuel Tank Certification
- TSSA Sub-Base Fuel Tank Pre-Certification
- Seismic Approval
- CSA-C282 Compliance
- CSA-Z32 Compliance

#### Cooling System Options:

- Remote Radiator (Horizontal or Vertical Options)
- Heat Exchanger(s)

#### Controller Options:

- 8-Relay Output Board
- 16-Light Remote Serial Annunciator Panel
- Insight Remote Monitoring Service
- Protocol Converter

#### Fuel System Options:

- Sub-Base Fuel Tank (diesel/bi-fuel units only)
- Inlet Filter (natural gas/propane/bi-fuel units only)
- Stainless Steel Flexible Fuel Connector

#### Miscellaneous Options:

- Alternator Anti-Condensation Heater
- Seismic Mounts
- Crankcase Ventilation Filter
- Permanent Load Bank (Loose)
- Oversized Alternator for increased motor starting

#### Circuit Breaker Options:

- 100% CSA Current Rating
- Thermal-Magnetic Emergency Power Breaker
- Electronic LI Emergency Power Breaker
- Electronic LSI Emergency Power Breaker
- Electronic LSI Emergency Power Breaker
- Unit-Mounted Load Bank Breaker

#### Enclosure Options:

- Skin-Tight Sound Enclosure - Floor Plate
- Walk-In Sound Enclosure  
(All enclosures c/w internal exhaust silencer to match enclosure dBA rating)
- Exhaust Stack Extension, 1m above encl. roof (Loose)
- CSA-C282 Enclosure Pkg. (Heater, Lighting & Panel)
- Exterior Load Bank Camlock Connections

#### Exhaust Options for Indoor Units:

- Exhaust Silencer (various grades & style available)
- Stainless Steel Flexible Exhaust Connector

#### Paralleling Options:

- Motorized Circuit Breaker
- Master Interface Panel (Loose)
- Custom Switchgear Controls Only (Field-Installed)
- Custom Switchgear c/w Controls (Factory-Installed)

#### Testing Options:

- Extended Duration Factory Test
- Witness Factory Acceptance Test
- Rated Power Factor Test
- CSA-C282 On-Site Start-Up Testing

#### Warranty Options:

- 2-Year / 1500-Hour Parts & Labour Standby
- 5-Year / 1500-Hour Parts & 2-Year Labour Standby
- 5-Year / 1500-Hour Parts & Labour Standby
- 1-Year / Unlimited-Hours Parts & Labour Prime Power

#### Maintenance Options:

- Basic Spares Kit: Oil & Fuel Filters plus Drive Belts
- Weekly Contract to CSA-C282 Table-2
- Monthly Contract to CSA-C282 Table-3
- Semi-Annual Contract to CSA-C282 Table-4
- Annual Contract to CSA-C282 Table-5
- Quinquennial Contract to CSA-C282 Table-6

**Looking for another option? Please contact Paramount Power Systems to find a suitable solution for you.**